

### ABSTRACT

This paper proposes the use of Embedded Z –source inverter system with fuzzy controller for Solar Photo Voltaic (PV) applications with adjustable speed drives. Closed loop operation FUZZY control strategies of EZSI system are proposed. EZSI produces the same voltage gain as Z-source inverter (ZSI) but due to the DC sources embedded within the X- shaped impedance network, it has the added advantage of inherent source filtering capability and also reduced capacitor sizing. This can be achieved without any extra passive filters. By controlling the shoot-through duty ratio and modulation index, EZSI system can produce any desired AC output voltage even greater than DC rail voltage and it also provides ride-through capability under voltage sag. These advantages are more significant for ASD to regulate the speed. The operational analysis and simulation results declared that EZSI is suitable for renewable energy applications to reduce the system complexity and thereby improving the efficiency of the inverter.

**KEYWORDS:** Adjustable Speed Drives(ASD), Embedded Z-source inverter(EZSI), fuzzy controller, PV array.

### INTRODUCTION

In recent days PV energy has drawn interest of the next generation energy source as capable of solving the problems of global warming and energy exhaustion caused by increasing day to day energy consumption. It depends on local climate, orientation and inclination of PV array with the Sun and also performance of the Inverter. The traditional Photo Voltaic systems contain Voltage source inverter and Current source inverter. They are either buck or boost but not buck-boost converter. The common problem of this topology is Shoot through will occur when two switches of the same phase leg is turned ON. This reduces the system reliability. To increase the system reliability and also to reduce the cost, the Z-source inverter as a single stage transformer less inverter topology is first proposed. To overcome the limitations and problems of the traditional or conventional source inverter Z-source inverter is proposed.

### Z-SOURCE INVERTER

It employs a special network that connects VSI and CSI where capacitor and inductor are used. The equivalent circuit is shown in fig-1. ZSI can be used for DC-to-AC, AC-to-DC, DC-to-DC or AC-to-AC power conversion. It employs a special impedance network to combine the converter main circuit to the dc power supply. It provides a single stage power conversion concept for secondary energy source such as photo electric system as they usually produce low variable DC voltage. It covers its modulation [5] and modeling control [6]. Therefore the ZSI can boost voltage and produce a required output voltage that is greater than the available dc bus voltage. In addition to this, the reliability of the inverter is greatly improved because the shoot through due to misgating can now no longer destroy the circuit. Thus it gives a low-cost, reliable, and high efficiency single stage structure for buck and boost power conversion [7]. The disadvantage is that chopping current is drawn from the source, if filter is not added. This chopping current raises the semi-conductor current rating and affects the maximum power point tracking for the renewable energy sources. So to overcome these drawbacks a new type of Z-source inverter called Embedded Z-Source inverter was proposed and designed.

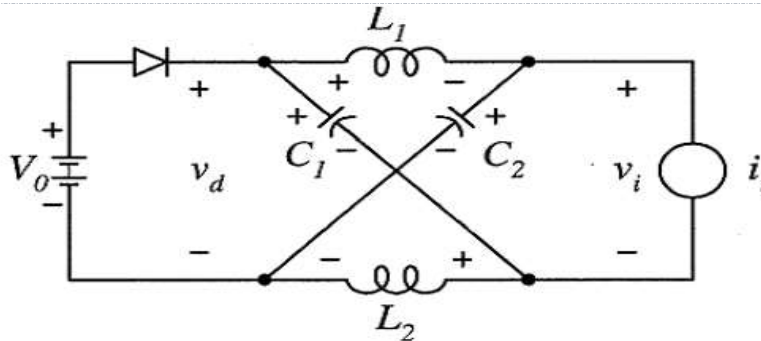

Fig-1: Z-Source inverter circuit

**EMBEDDED Z-SOURCE INVERTER**

The equivalent circuit of EZ-Source inverter fed induction motor is shown in Fig-2. The proposed system is EZSI with PI and also with Fuzzy controller. It has two DC sources embedded within the X-shaped network to filter the currents drawn from two DC sources of  $V_{dc}/2$ . This costs high but the advantages are more which overcomes the limitations of ZSI. These advantages are analyzed by the operating principle of the inverter. Inverter has three operating states.

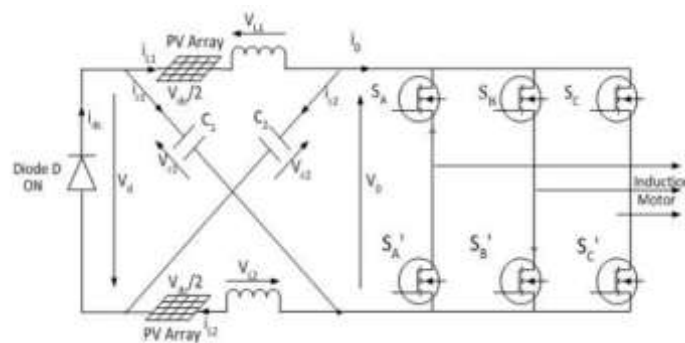

Fig. 2: EZ-source inverter circuit

**E-Z network design**

To realize the operation of EZSI, design calculations have been provided assuming that

$$V_{dc}=110V, B=3.8, R=1\Omega, \Delta I=0.4A, \delta=T_o/T$$

$$B = \frac{1}{1-2\delta} \Rightarrow \delta=0.368 \quad (01)$$

The design considerations of various elements of the E-Z network are as follows

**Inductor**

In VSI mode of operation the input voltage appears across the capacitor and only pure DC current flows across the inductor. In shoot-through mode, the inductor current increases linearly and the inductor voltage is the same as the capacitor voltage ( $V_L=V_c=V$ ). But in non-shoot-through mode the inductor current decreases linearly and the voltage across the inductor is the difference between the input voltage and capacitor voltage. The average current through the inductor is

$$\tilde{I}_L = \frac{P}{V_{dc}} \quad (02)$$

The value of the inductor is:

$$L = \frac{V_{dc} \delta}{f \Delta I} = 10mH \quad (03)$$

Where  $\Delta I$  = Inductor maximum current - inductor minimum current (60% peak to peak ripples chosen) and is assumed as 0.4.

**Capacitor**

The capacitor value is given by formula  $C = \delta / (2fR) = 18F \quad (04)$

**Peak DC link voltage**

The Peak DC link voltage is given by formula  $\widehat{V}_l = 3.8 * V_{dc} = 418V$  (05)

**Capacitor voltage**

The Capacitor voltage is given by formula  $V_{C1} = V_{C2} = 3.78 * \frac{V_{dc}}{2} = 208V$  (06)

**Output phase voltage**

The Output phase voltage is given by formula  $\widehat{V}_{AC} = 3.42 * \frac{V_{dc}}{2} = 188.1V$  (07)

**FUZZY LOGIC CONTROLLER**

In recent years, the number and variety of applications of fuzzy logic have increased significantly. The applications range from consumer products such as cameras, camcorders, washing machines, and microwave ovens to industrial process control etc.

To understand the growth in use of fuzzy logic, one must first understand the meaning of fuzzy logic. Fuzzy logic has two different meanings. In a narrow sense, fuzzy logic is a logical system, which is an extension of multivalve logic. However, in a wider sense fuzzy logic (FL) is almost synonymous with the theory of fuzzy sets, a theory which relates to classes of objects with unsharp boundaries in which membership is a matter of degree.

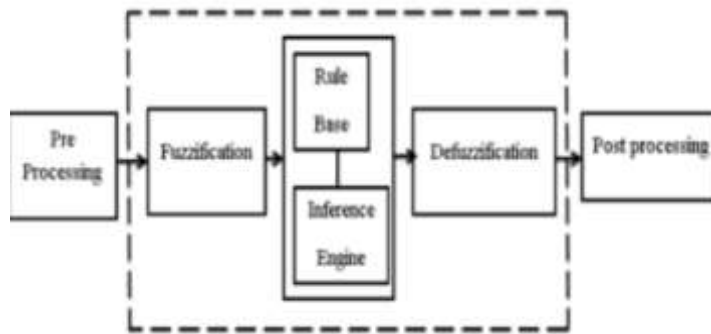

Fig-3: Fuzzy Model

Membership function values are assigned to the linguistic variables, using seven fuzzy subsets: NB (Negative Big), NM (Negative Medium), NS (Negative Small), ZE (Zero), PS (Positive Small), PM (Positive Medium), and PB (Positive Big).

Change In Error	Error						
	NB	NM	NS	Z	PS	PM	PB
NB	PB	PB	PB	PM	PM	PS	Z
NM	PB	PB	PM	PM	PS	Z	Z
NS	PB	PM	PS	PS	Z	NM	NB
Z	PB	PM	PS	Z	NS	NM	NB
PS	PM	PS	Z	NS	NM	NB	NB
PM	PS	Z	NS	NM	NM	NB	NB
PB	Z	NS	NM	NM	NB	NB	NB

Table 1. Fuzzy Rules

The fuzzy rules are shown in Table 1. Based on these rules we design the fuzzy controller.

This gives the basic idea to design the fuzzy logic controller. The FIS Editor handles the high level issues for the system: How much input and output variables? What are their names? The Fuzzy Logic Toolbox doesn't limit the number of inputs. However, the number of inputs may be limited by the available memory of your machine. If the number of inputs is too large, or the number of membership functions is too big, then it may also be difficult to analyze the FIS using the other GUI tools.

**SIMULATION AND RESULTS**

The performance of the solar cell powered EZSI fed induction motor with PI controller and also with FUZZY controller have been simulated and presented.

**EZSI with PI controller**

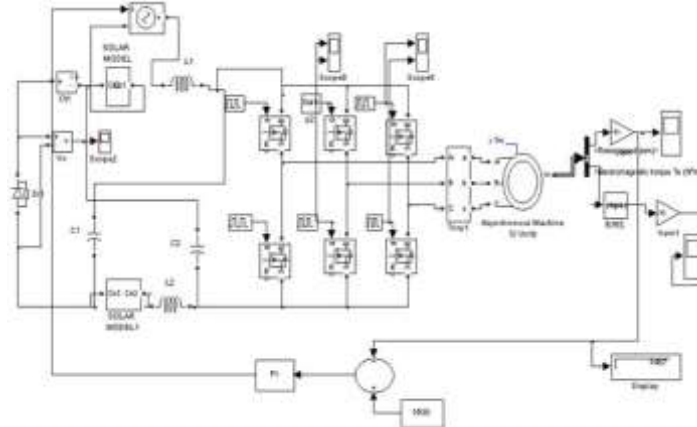
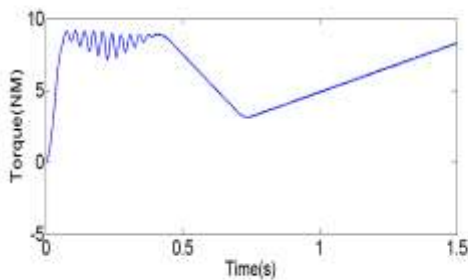

**Fig-4: Simulink model of closed loop EZSI**

Circuit model of closed loop controlled induction motor drive system is shown in fig.4. The output AC voltage is sensed and compared with reference voltage. The error generated is given to the PI controller to regulate the output voltage with respect to input voltage. The speed response of the closed loop system is shown in fig. 6. It seems that speed of the motor increases and then reduces to set value. The Torque variation is shown in fig.5 Line voltage and current waveform are shown .This shows that closed loop system is able to regulate the speed.

**Simulation results of EZSI with PI controller**

The simulation results of EZSI with PI controller are shown in this section. The speed, Torque, voltage and current waveforms are shown.



**Fig-5: Torque waveform**

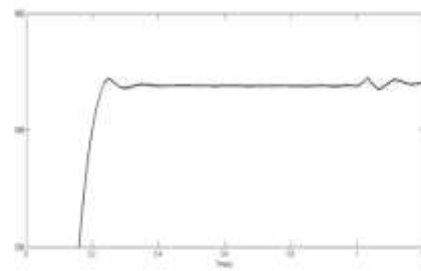

**Fig-6: speed waveform**

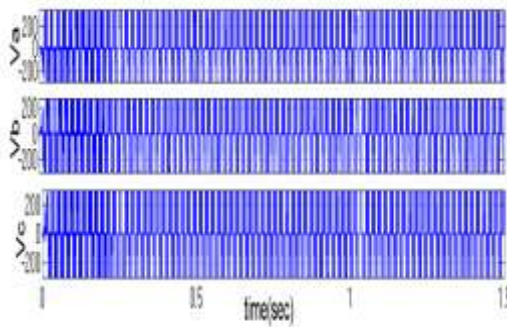

**Fig-7: voltage waveform**

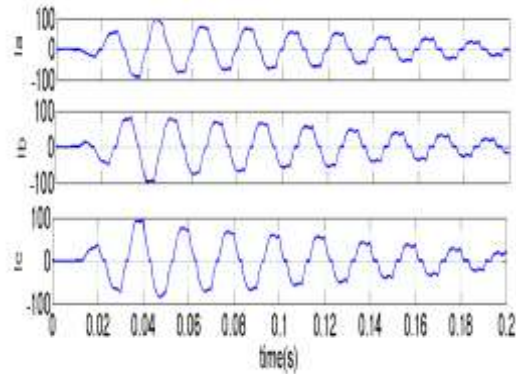

**Fig-8: Current waveform**

The Torque waveform is shown in Fig-5. Maximum torque occurs in between 8 and 10. After 0.5 s it falls at 3 and again increases and attains steady state. The speed waveform is shown in Fig-6. It increases linearly with time and overshoot occurs at 1490 rpm .It attains steady state after 1 second. The waveform doesn't have smooth it contains some ripples. The voltage waveform is shown in fig-7. Voltage is maximum at 500 V. The current waveform is shown in fig-8.The current is maximum in between 50 to 60 Amperes and gradually decreases the maximum value.

**EZSI with fuzzy controller**

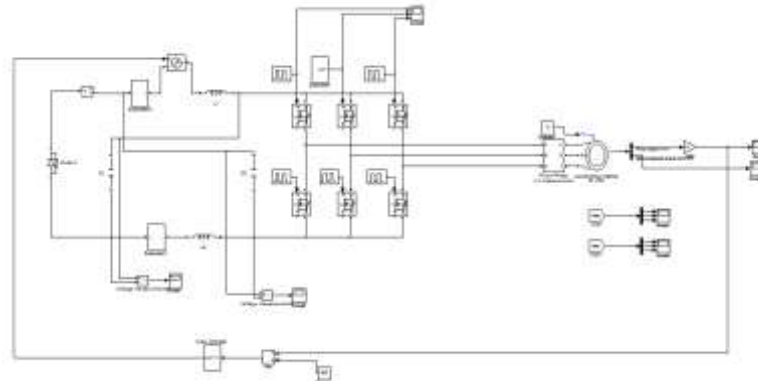

**Fig-9: Simulation model of closed loop fuzzy controller**

**Simulation Results of closed loop fuzzy controller**

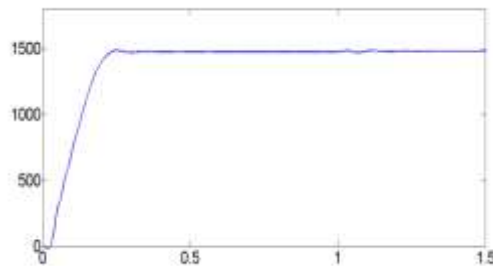

**Fig -10:speed waveform**

The speed waveform is shown in fig-10. The speed increases linearly with time. It attains the steady state at 0.5seconds.Torque, voltage and current waveforms are same as EZSI with PI controller.



## CONCLUSIONS

In this paper closed loop controlled EZ-source inverter with fuzzy controller for Photo Voltaic applications is proposed. The advantages of EZSI are lower voltage/ current stresses and implicit source filtering are gained without adding extra hardware. It seems that small ratings of passive components are adequate to compensate the unpredictable solar input. So EZSI can able to regulate the speed. Thereby efficiency of induction motor drive can be improved. Therefore EZSI with fuzzy controller can decrease the overshoot and it reaches the steady state response quickly and the curve is smooth without any ripples when compared to EZSI with PI controller. The simulation results show that it can able to regulate the speed with improved performance.

## REFERENCES

- [1] R. Caceres and I. Barbi, "A boost dc-ac converter operation, analysis control and experimentation," in Proc. Int. Conf. Industrial Electronics, Control and Instrumentation (IECON'95), Nov. 1995, pp. 546–551.
- [2] "A boost dc-ac converter Design, Simulation and implementation," in Proc. Power Electronic Brazilian Conf. (COBEP'95), Dec. 1995, pp. 509–514.
- [3] N. Vazquez, J. Almazan, J. Alvarez, C. Aguilar, and J. Arau, "Analysis and experimental study of the buck, boost and buckboost inverters," in Proc. IEEE 30th Annu. Power Electron. Spec. Conf., vol. 2, pp. 801–806, 1999.
- [4] B. J. Almazan, N. Vazquez, C. Hernandez, J. Alvarez, and J. Arau, "A comparison between the buck, boost and buck-boost inverters," in Proc. IEEE 7th Int. Power Electron. Congr., pp. 341–346, 2000.
- [5] P. C. Loh, D. M. Vilathgamuwa, Y. S. Lai, G. T. Chua, and Y. Li, "Pulse-width modulated Z-source inverter," IEEE Trans. Power Electron., vol. 20, no. 6, pp. 1346–1355, Nov. 2005.
- [6] J. W. Jung and A. Keyhani, "Control of a fuel cell based Zsource converter," IEEE Trans. Energy Convers., vol. 22, no. 2, pp. 467–476, 2007.
- [7] M. Shen, J. Wang, A. Joseph, F. Z. Peng, L. M. Tolbert, and D. J. Adams, "Constant boost control of the Zsource inverter to minimize current ripples and voltage stress," IEEE Trans. Ind. Appl., Vol. 42, No. 3, pp. 770–778, 2006.